

 TREASURE GARDEN

UCP410-ST 10'*STAR* **Commercial**

Assembly and Operation Guide



Thank you for purchasing Treasure Garden's Stardust Umbrella.

Please remove all contents from the package, inspect and review checklist.

CHECKLIST

- A - (1) Finial
- B - (1) Canopy/Mainframe

A - 

B -

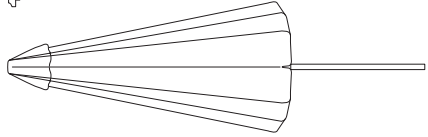

STEP 1 Set Up

Carefully remove umbrella from box. Attach finial to top of canopy/mainframe by turning clockwise.

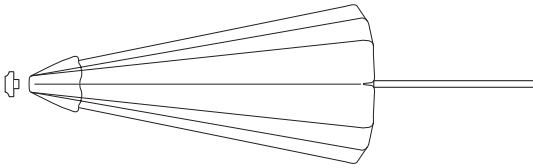

STEP 2 Opening Umbrella

Turn the umbrella upright and insert in free standing base or through center of table. Push center hub up pole until it pops open to its fully open position. Insert pin through hole on pole to secure in place.

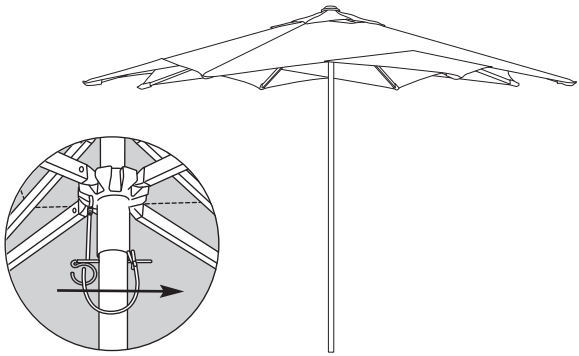

STEP 3 Closing Umbrella

Remove pin from center pole and pull hub down pole to bring umbrella back to its original upright position. Tie canopy to secure when not in use.

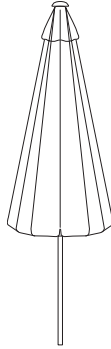

S A F E T Y P R E C A U T I O N S :

- Close the umbrella in windy conditions or when a storm approaches.
Never allow the umbrella to flap in the wind; this could damage the canopy.
- Do not leave open umbrella unattended. If damage occurs, this is not covered by the warranty.
- When adjusting the umbrella, make sure that no person(s) or item(s) are close to the umbrella. This is important to prevent injury or material damage.

C A R E A N D M A I N T E N A N C E :

- When not in use, close and cover umbrella with a protective cover (sold separately).
- Allow a wet canopy to dry opened up.
- If necessary, clean the fabric with lukewarm water, mild detergent, and a sponge.
- Wipe sliding marks on the aluminum poles with a damp cloth.

Winter Storage:

- Store in a dry, protective place.

After the Winter:

- Check the condition and function of the umbrella. Any defects must be repaired by a professional.

WARRANTY:

Treasure Garden warrants this product to be free from defects in original materials and workmanship for a period of 3 years from the date of purchase. If a defect in the original material or workmanship appears during the warranty period; Treasure Garden will (at its option) repair or replace the product without charge. Limited warranty against fabric fading, depending on fabric.

Simply contact your original authorized Treasure Garden dealer with a description of the defect. The dealer will verify the defect and work closely with Treasure Garden to obtain the necessary service. In many cases, simple problems can be solved with a replacement part that can be shipped directly to the dealer for professional installation/repair.

In the event that warranted factory service is required, Treasure Garden will assume the responsibility of the return freight charges on warranted product for the 2 years only.

Returned product that (upon receipt and inspection) is deemed to be "not covered" under our warranty, will be shipped/billed at your expense.

This warranty gives you specific legal rights, and you may have other rights which vary from state to state.

NOTE: Failure caused by unreasonable or abusive use, or failure caused by neglect of reasonable and necessary care are not covered by this warranty.

Additionally, acts of nature (including but not limited to wind, hurricanes, tornadoes, and storms) are not covered by this warranty.



www.treasuregarden.com

©2017 Treasure Garden, Inc. - All Rights Reserved.

7/17