

 TREASURE GARDEN™

---

**User Guide**

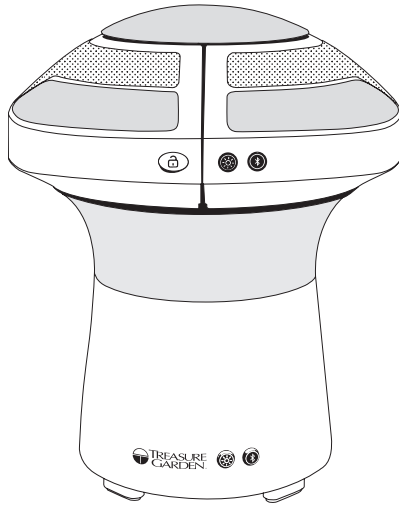

**EVO**



**EVO** *Dual-Light Sound Pod*

Thank you for purchasing Treasure Garden's EVO Dual-Light Sound Pod.  
Please remove all contents from the package, inspect and review checklist.

## CHECKLIST

A - (1) EVO

B - (1) Power Supply\*

*\*Note: Use only the power supply included with EVO.  
See page 6 for Safety Precautions. ⚠*

A -

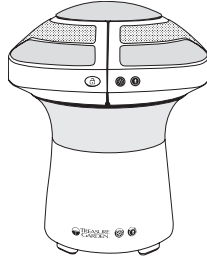

B -



### Front View

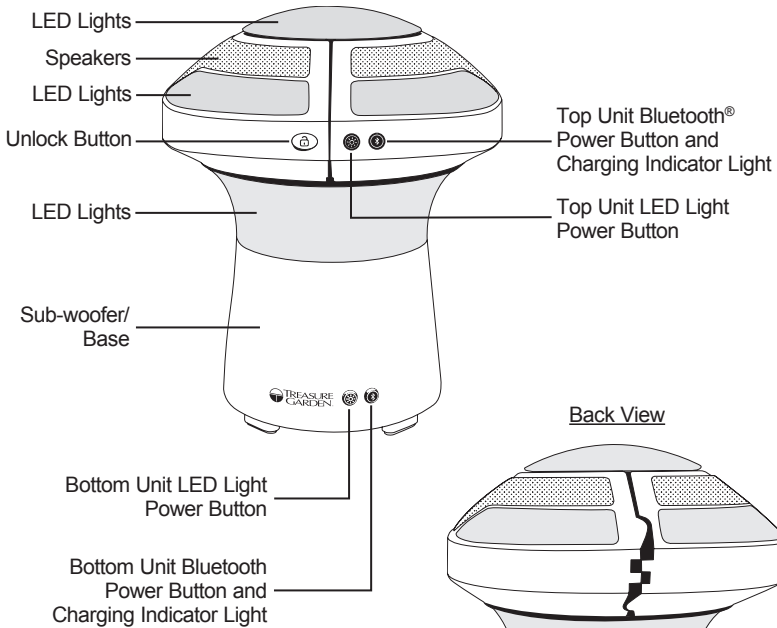

### Back View

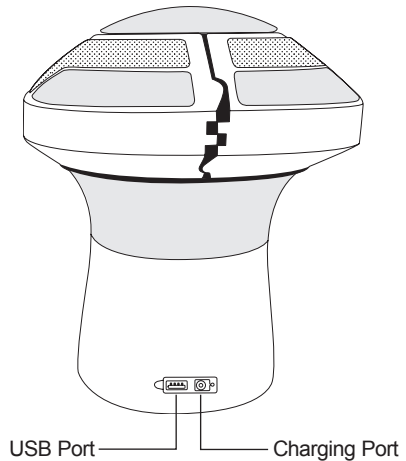

## STEP 1

## CHARGING

- Remove protective cap from charging/USB port and connect the power supply to the EVO charging port, then plug the other end into any 110V power source. The EVO is fully charged when the red Bluetooth indicator lights turn off (approximately 3 hours).

### Note:

- Charge EVO in dry area to keep from damaging.
- Top unit must be installed on bottom unit correctly to charge. Make sure buttons on top unit and bottom unit align prior to connection power supply.
- We recommend fully charging EVO before you store for extended periods of time.

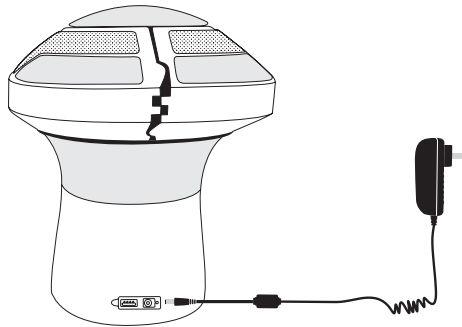

## STEP 2

## PAIRING BLUETOOTH DEVICE

- To turn on Bluetooth, locate the Bluetooth power button on the top unit of the EVO. Press and hold Bluetooth power button for 3 seconds until you hear a prompt sound. The Bluetooth indicator light will blink white when in pairing mode.
- From your music device, turn on Bluetooth and switch your device to discovery mode. Select "EVO" from your device options. You will hear a set tone and the Bluetooth light will become solid white once the EVO and your music device are paired successfully.
- To turn on bass speaker, locate the Bluetooth power button on bottom unit. Press and hold Bluetooth power button for 3 seconds until you hear a prompt sound. The Bluetooth indicator light will blink white first, followed by a set tone, and then become solid white. Your music device and EVO top and bottom unit are now paired successfully.
- Use controls on music device to select songs from playlists and adjust volume.

### Note:

- Sound quality will lessen or music will stop playing when music device is approximately 100 feet away from EVO.

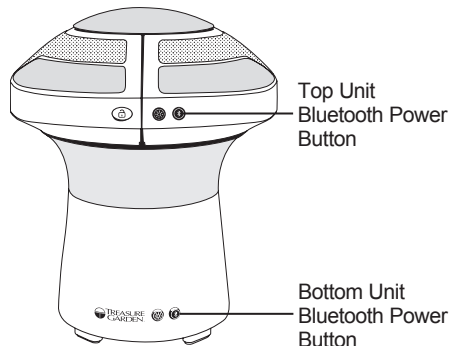

## STEP 3 UNPAIRING BLUETOOTH DEVICE

- Only 1 music device can be connected at a time.
- To pair another device, first unpair the current device by disconnecting Bluetooth on the device, or by pressing Bluetooth power button twice rapidly on top unit. You will hear a tone when the current music device unpairs and the Bluetooth light will begin blinking white again.

**Note:**

- If you press Bluetooth power button once, the music device will pause. Press once again and music will resume.

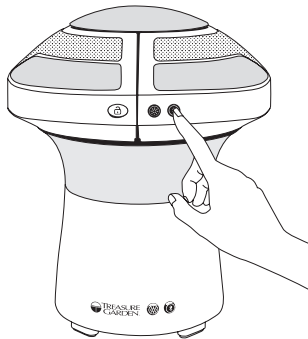

## STEP 4 TURNING DEVICE OFF

- To turn off EVO, press and hold Bluetooth power button on top unit for 4 seconds. You will hear a descending tone and Bluetooth Indicator lights will turn off. Both top and bottom units will be disconnected.

**Note:**

- EVO will turn off automatically when Bluetooth is in pairing mode, or inactive for more than 15 minutes.
- When your music device is disconnected, you will hear a prompt sound from EVO.

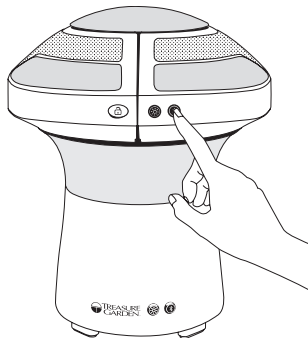

## STEP 5 LED LIGHTS

- To turn on and turn off LED lights, press the LED light power button located on top and bottom units.

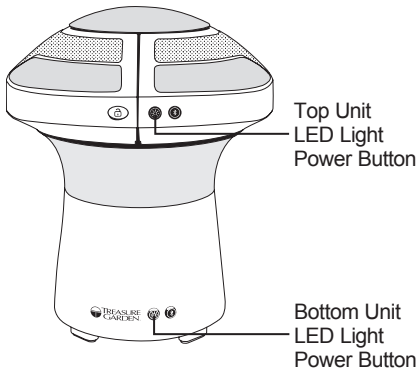

## STEP 6 ATTACHING EVO TO UMBRELLA

- The top unit of the EVO can be attached to umbrella center poles up to 2" and cantilever umbrella light adapters.
- Open EVO by holding the device firmly with one hand and then press "unlock" button with the other hand to release the clamp lock.
- Open up the EVO top unit, remove from Bottom unit, and clasp around the mid pole or light adapter. Snap to close.

### Note:

- When reattaching top unit to bottom, make sure the buttons on the top and bottom unit align. Note the grooves on top unit only line up one way.
- Doing so will cause damage to electrical components.

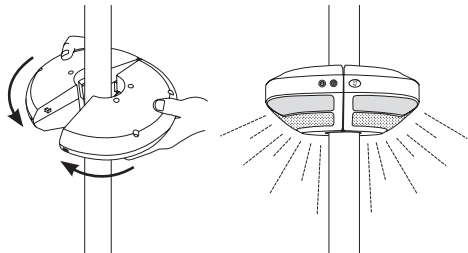
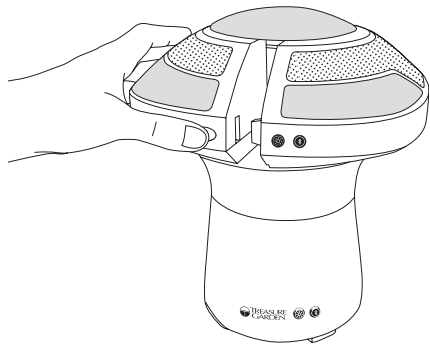

**STEP****TABLE LIGHT**

- With the top unit removed, press down adapter rod until rod locks into place.

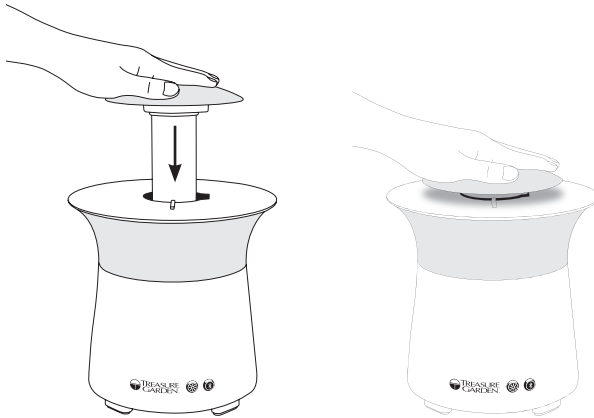
**STEP 8****USB PORT**

- To charge electronic devices, remove protective cap from charging/USB port. Insert USB cable into USB port located on back of bottom unit. Reattach protective cap when not in use.

**Note:**

- If using USB port and lights, battery life will reduce to 4 hours.



## SAFETY PRECAUTIONS

- Position the EVO in a location that will protect it from direct sunlight and moisture.
- Do not overcharge the battery. Unplug the power supply when the indicator light turns off. Over charging may cause the battery to become hot, rupture or ignite. If you see any heat deformation or leakage, properly dispose of the device.
- If unit is exposed to light moisture, allow unit to air dry for a minimum of 24 hours before reuse.
- Power supply must be used indoors only. It is neither designed nor tested for use outdoors.

**WARNING:** *The EVO Dual-Light Sound Pod is not waterproof.* If the EVO is immersed in water or exposed to heavy rain the unit will be damaged and void the 1 year warranty.

**NOTE:** We recommend fully charging EVO before you store for extended periods of time.

### Power Supply:

- Never use a third party battery or power supply. Doing so may increase risk of fire or explosion. Contact your local authorized dealer for a replacement power supply.
- During prolonged use, it is normal for the power supply to be warm to the touch. When using power supply, avoid direct sunlight and exposure to moisture.
- To prevent damage to the electrical components, do not use the charging or USB port in inclement weather (rain, snow).

### Power Supply Information

Input voltage: 100-240Vac 50/60Hz 1.6A

Output: 9.2V 2.5A

5' Cord

### USB Information

USB 2.0 Output: 5V 1A



The Bluetooth® word mark and logos are registered trademarks owned by Bluetooth SIG, Inc. and any use of such marks by Treasure Garden is under license.

**WARRANTY:**

Treasure Garden warrants this product (for residential use ONLY) to be free from defects in original materials and workmanship for a period of 1 year from the date of purchase. If a defect in the original material or workmanship appears during the warranty period; Treasure Garden will (at its discretion) repair or replace the product without charge.

Simply contact your original authorized Treasure Garden dealer with a description of the defect. The dealer will verify the defect and work closely with Treasure Garden to obtain the necessary service. In many cases, simple problems can be solved with a replacement part that can be shipped directly to the dealer for professional installation / repair.

There are no serviceable parts within this product, DO NOT OPEN. Tampering with or altering the product will void warranty.

In the event that warranted factory service

is required, Treasure Garden will assume the responsibility of the return freight charges for the first year only.

Returned product that (upon receipt and inspection) is deemed to be "not covered" under our warranty, will be shipped / billed at your expense.

This warranty gives you specific legal rights, and you may have other rights which vary from state to state.

**RUST:** Rust is a natural part of the aging process of steel or iron based materials, and is therefore NOT considered a defect.

**NOTE:** Failure caused by unreasonable or abusive use, or failure caused by neglect of reasonable and necessary care are not covered by this warranty.

Additionally, acts of nature (including but not limited to wind, hurricanes, tornadoes, and storms) are not covered by this warranty.



[www.treasuregarden.com](http://www.treasuregarden.com)

©2020 Treasure Garden, Inc. - All Rights Reserved.  
v.12.08.20